

SECTION B-B

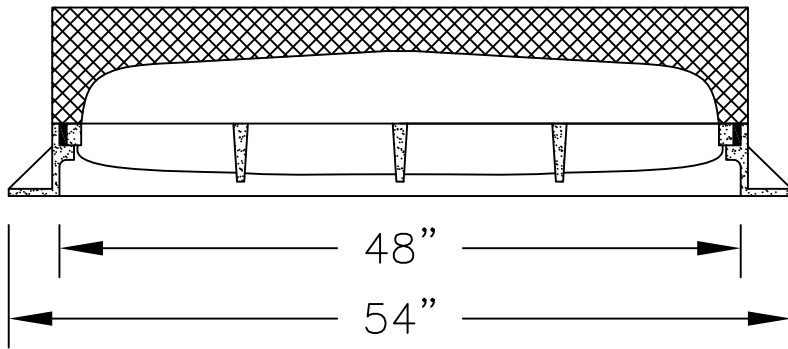

SECTION A-A

OPTION AVAILABLE FOR 4", 6",
8" AND 10" CURB REVEAL

SPECIFICATIONS:

MINIMUM CONCRETE STRENGTH 4000 PSI @ 28 DAYS
 MATERIALS AND WORKMANSHIP IN ACCORDANCE WITH THE REQUIREMENTS
 OF THE NEW JERSEY DEPARTMENT OF TRANSPORTATION
 STEEL REINFORCEMENT A615 GRADE 60 HORIZONTAL AND VERTICAL

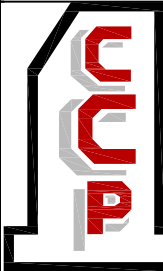

**Continental
Concrete
Products, Inc.**
 1 South Grosstown Rd.
 Pottstown, PA 19464
 Phone: (610) 327-3700
 Fax: (610) 327-9488

**NJDOT TYPE B INLET TOP UNIT
(BICYCLE GRATE)**

SIGNATURE OF APPROVAL

DATE | AR | DWG

2/08/16

NJB

STRUCTURE