

END ELEVATION

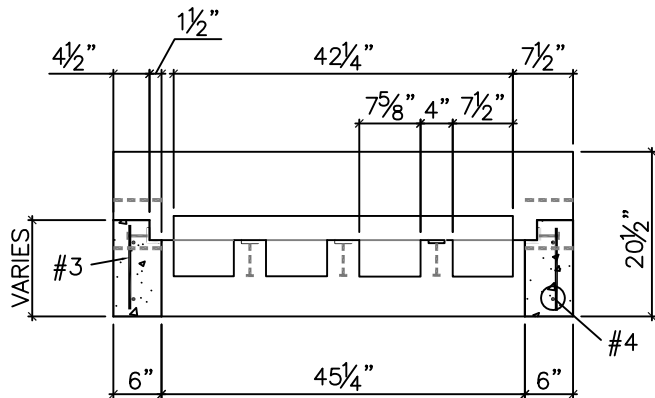

SECTION A-A

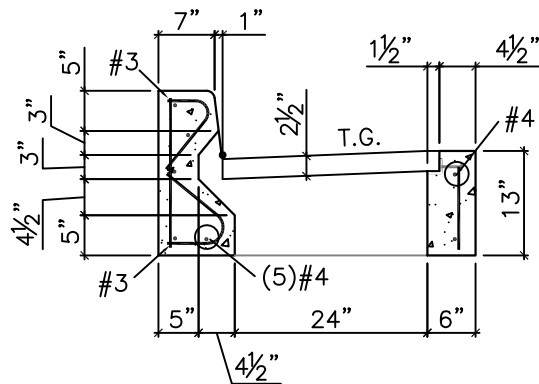

SECTION B-B

SPECIFICATIONS:

MINIMUM CONCRETE STRENGTH 4000 PSI @ 28 DAYS (PENNDOT CLASS AA)
 MATERIALS AND WORKMANSHIP IN ACCORDANCE WITH THE REQUIREMENTS
 OF PENNDOT PUBLICATION 408 SECTION 605 & 714
 STEEL REINFORCEMENT A615 GRADE 60 HORIZONTAL AND VERTICAL
 WEIGHT: 1500 LBS.

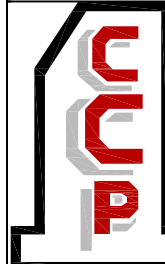

**Continental
 Concrete
 Products, Inc.**
 1 South Grosstown Rd.
 Pottstown, PA 19464
 Phone: (610) 327-3700
 Fax: (610) 327-9488

PENNDOT 4' TYPE C INLET TOP
 (RC-45M DESIGN)

SIGNATURE OF APPROVAL

DATE

AR

DWG

STRUCTURE

2/08/16

45MCTOP