

PIPE SIZE	A	B
12" $\phi$	12" $\phi$	18" $\phi$
15" $\phi$	15" $\phi$	21" $\phi$
18" $\phi$	18" $\phi$	26" $\phi$

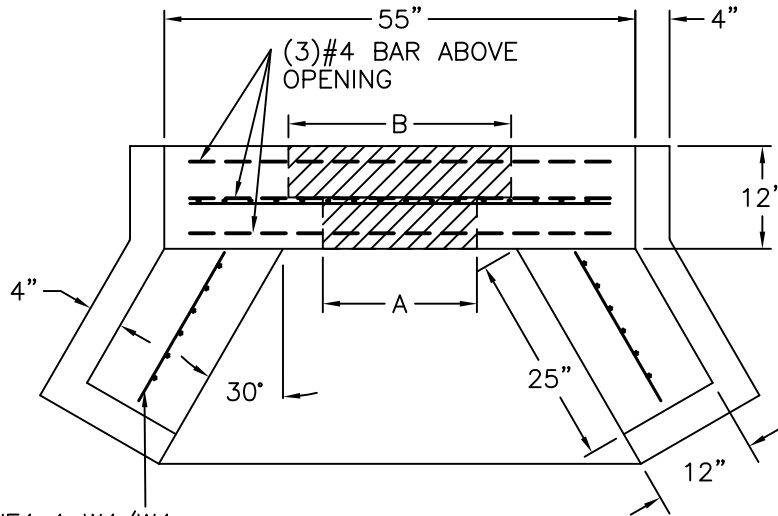

WWF4x4 W4/W4  
ALL WALLS AND  
HEADWALL

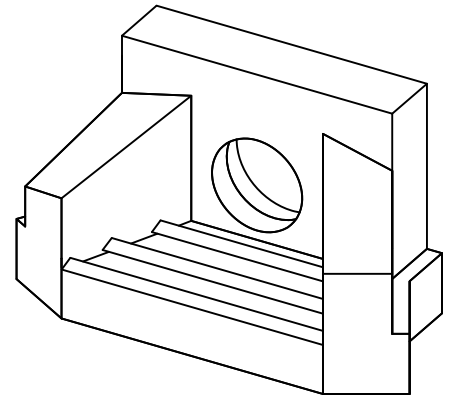
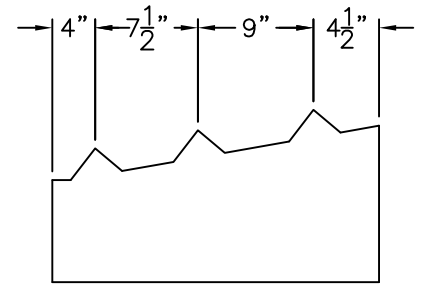

APRON DISSIPATER DETAIL

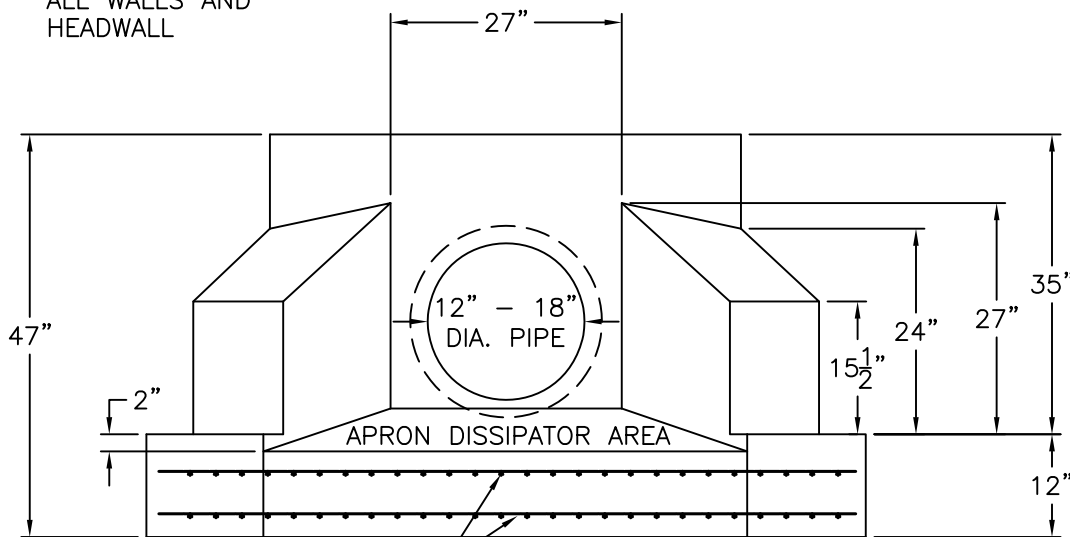

WWF4x4 W6.7/W6.7

MAXIMUM WEIGHT 3.0 TONS

**SPECIFICATIONS:**

- MINIMUM CONCRETE STRENGTH 4000 PSI @ 28 DAYS (PENNDOT CLASS AA)
- DW ENDWALL DESIGNED AS PER PENNDOT SPECIFICATION
- EXPOSED EDGES TO HAVE 1" X 1" CHAMFER
- MATERIALS AND WORKMANSHIP IN ACCORDANCE WITH THE REQUIREMENTS OF PENNDOT PUBLICATION 408 SECTION 605 & 714
- STEEL REINFORCEMENT A615 GRADE 60 HORIZONTAL AND VERTICAL

**Continental  
Concrete  
Products, Inc.**  
1 South Grosstown Rd.  
Pottstown, PA 19464  
Phone: (610) 327-3700  
Fax: (610) 327-9488

**PENNDOT TYPE 'DW' ENDWALL FOR  
12"  $\phi$ , 15"  $\phi$  & 18"  $\phi$  PIPE**

SIGNATURE OF APPROVAL

DATE | AR | DWG

2/08/16

DW1218

STRUCTURE