

NOTE:
 PRECAST DROP MANHOLE CAN ONLY BE USED FOR 8" PVC SDR-35 PIPE. DROP PIPE ASSEMBLY AND CONNECTION TO BASE TO BE DONE BY OTHERS.

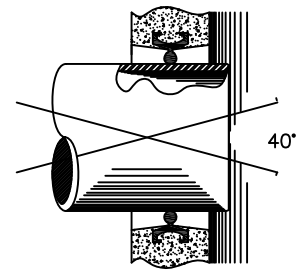

PIPE TO MANHOLE SEAL STAR-SEAL™ GASKET PER ASTM RUBBER GASKET SPECS C923, JOINT ALLOWS 20° OMNIDIRECTIONAL DEFLECTION

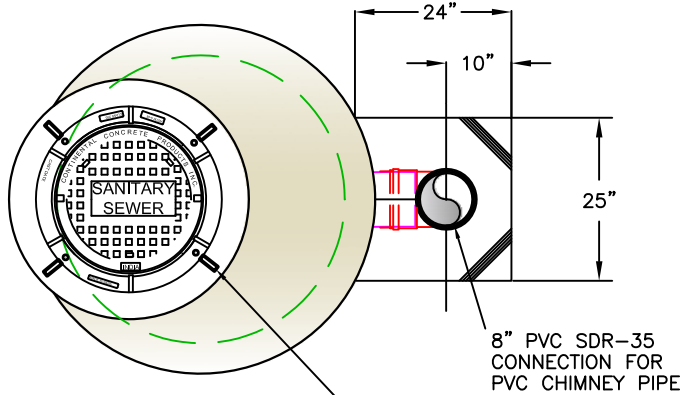
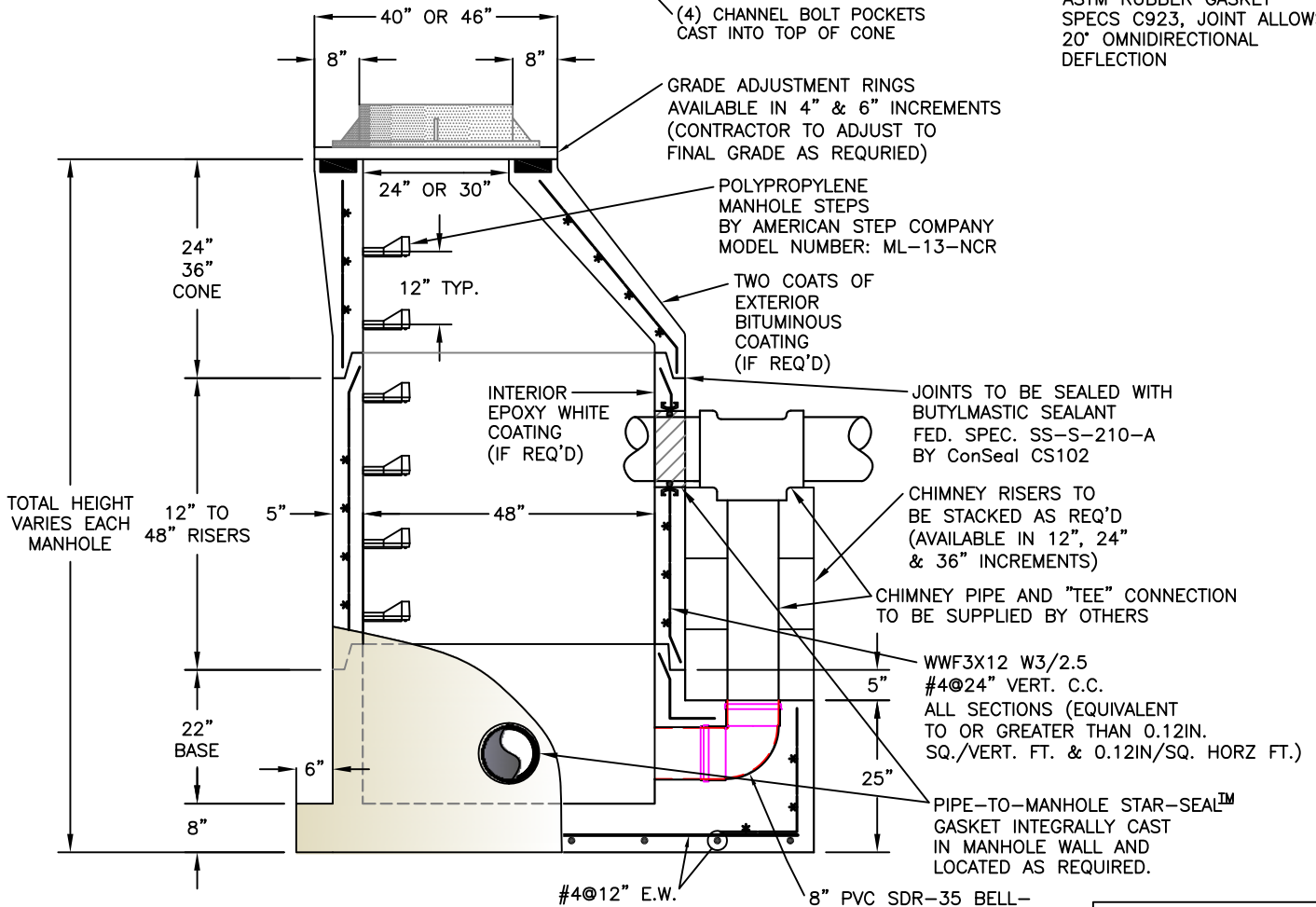

SPECIFICATIONS:

PVC LINING AVAILABLE IF REQUIRED.
 MEETS PENNDOT PUBLICATION 408.
 MINIMUM CONCRETE STRENGTH 4000 PSI @ 28 DAYS
 STEEL REINFORCEMENT ASTM A185 HORIZONTAL & VERTICAL STEEL
 1 1/2" MIN. CONCRETE COVER (ALL REINFORCEMENT)
 MANHOLE DESIGN SPEC. CONFORM TO "PRECAST REINFORCEMENT MANHOLE SECTIONS" ASTM C478, LATEST REVISION.

STAR-SEAL™ GASKET TO BE USED FOR 4" UP TO 16" PIPE. BOOT GASKET TO BE USED FOR PIPE > 16".

**Continental
 Concrete
 Products, Inc.**
 1 South Grosstown Rd.
 Pottstown, PA 19464
 Phone: (610) 327-3700
 Fax: (610) 327-9488

**48" DIA. SANITARY SEWER DROP MANHOLE
 w/STAR-SEAL™ PIPE TO MANHOLE GASKET**

SIGNATURE OF APPROVAL	DATE	AR	DWG	STRUCTURE
	2/08/16		48DSMH	