

SECTION VIEW

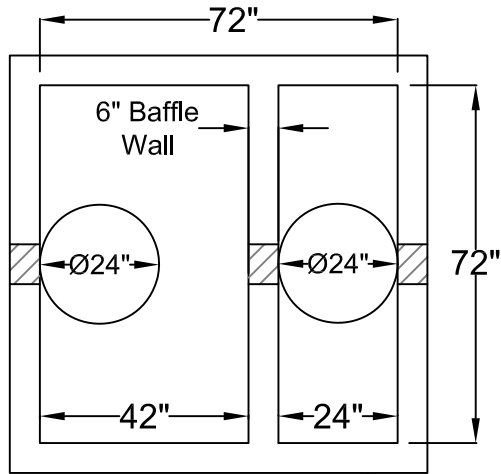

Bituminous Exterior Coating(Optional)

PLAN VIEW

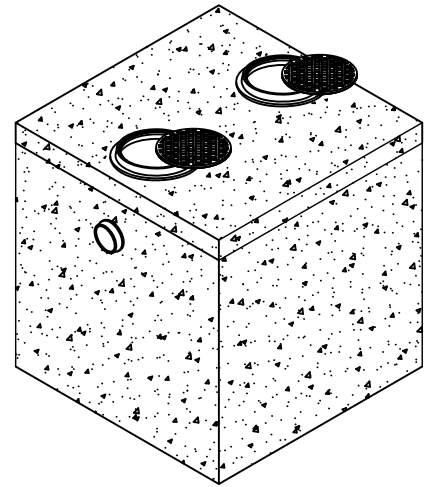

#4 @ 8" E.W.
Top & Bottom

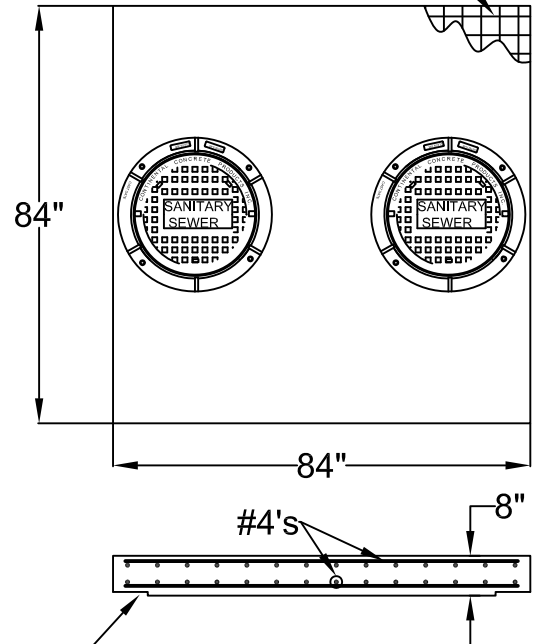

7" X 3/4" DAP
AROUND ENTIRE
PERIMETER OF LID

CONVERSION LID

SPECIFICATIONS:

- ALL PIPE PENETRATION SIZE & LOCATIONS ARE TO BE VERIFIED BEFORE FABRICATION.
- ALL INTERNAL PIPING SUPPLIED & INSTALLED BY OTHERS (IF REQUIRED).
- INTERIOR WHITE EPOXY COATING AVAILABLE UPON REQUEST.
- MATERIAL AND CONSTRUCTION SHALL COMPLY WITH PENNDOT PUB. 408.
- PENNDOT CLASS AA CONCRETE 4500 PSI @ 28 DAYS.
- REINFORCEMENT~ASTM A615 GRADE 60, MIN. 1 1/2" COVER.
- H-20 LOAD RATING.



**Continental
Concrete
Products, Inc.**

1 South Grosstown Rd.
Pottstown, PA 19464
Phone: (610) 327-3700
Fax: (610) 327-9488

1500 GALLON GREASE TRAP
(72" W X 72" L X 84" H ID VAULT)

SIGNATURE OF APPROVAL

DATE AR DWG

STRUCTURE

2/08/16

1500GT