

SECTION VIEW

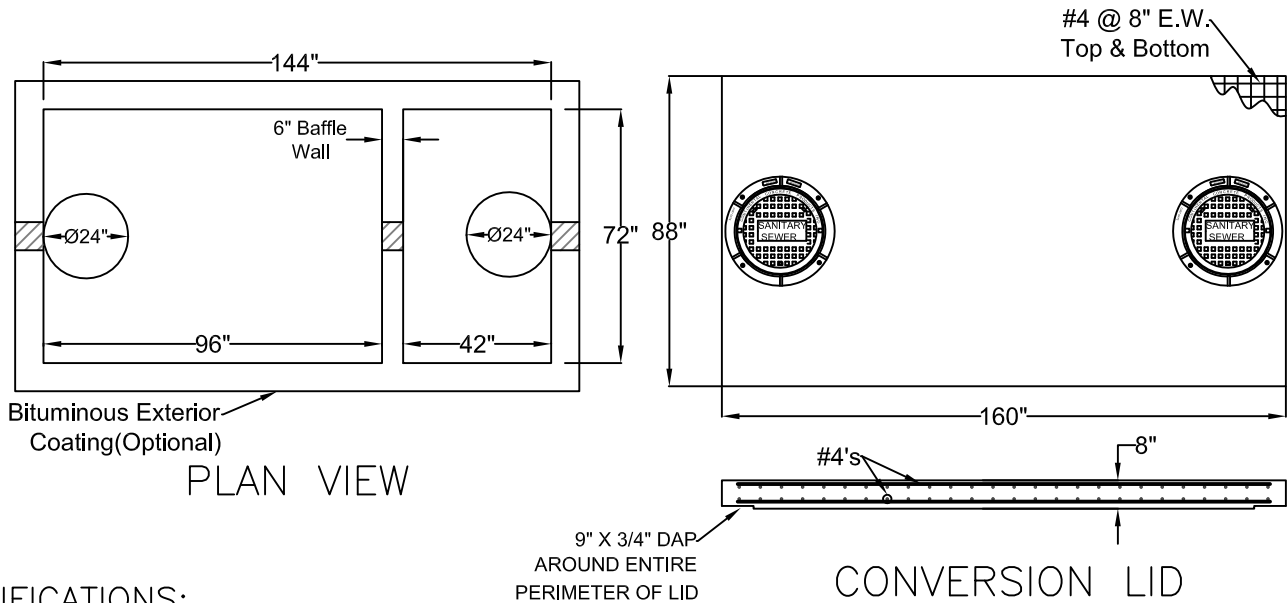
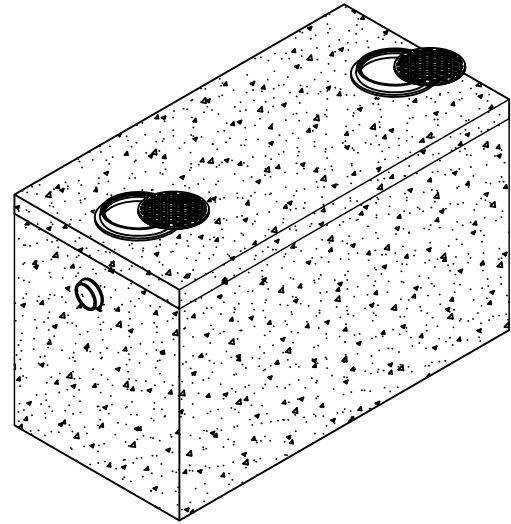

PLAN VIEW

CONVERSION LID

SPECIFICATIONS:

- ALL PIPE PENETRATION SIZE & LOCATIONS ARE TO BE VERIFIED BEFORE FABRICATION.
- ALL INTERNAL PIPING SUPPLIED & INSTALLED BY OTHERS (IF REQUIRED).
- INTERIOR WHITE EPOXY COATING AVAILABLE UPON REQUEST.
- MATERIAL AND CONSTRUCTION SHALL COMPLY WITH PENNDOT PUB. 408.
- PENNDOT CLASS AA CONCRETE 4500 PSI @ 28 DAYS.
- REINFORCEMENT~ASTM A615 GRADE 60, MIN. 1 1/2" COVER.
- H-20 LOAD RATING.

Continental Concrete Products, Inc.
 1 South Grosstown Rd.
 Pottstown, PA 19464
 Phone: (610) 327-3700
 Fax: (610) 327-9488

2000 GALLON GREASE TRAP
 (72"W X 144"L X 66"H ID VAULT)

SIGNATURE OF APPROVAL	DATE	AR	DWG	STRUCTURE
	2/08/16		2000GT	