

SECTION VIEW OF COVER

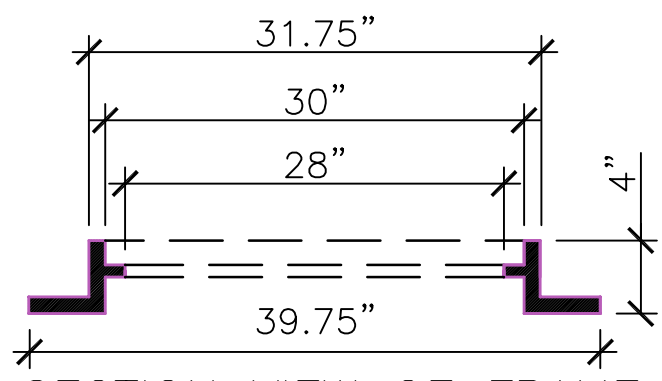

SECTION VIEW OF FRAME

SPECIFICATIONS:

- ALL MATERIAL IS ASTM A48 CLASS 35B GRAY IRON.
- ALL MATERIAL IS BITUMINOUS COATED.
- (4) 1" DIAMETER BOLT HOLES IN FRAME
- TOTAL WEIGHT IS 390 LBS.
- SUITABLE FOR H25 LOAD DESIGN.



**Continental
Concrete
Products, Inc.**
1 South Grosstown Rd.
Pottstown, PA 19464
Phone: (610) 327-3700
Fax: (610) 327-9488

30" DIA. STORM SEWER FRAME AND COVER
(28" Ø CLEAR OPENING IN FRAME)

SIGNATURE OF APPROVAL	DATE	AR	DWG	STRUCTURE
	2/08/16		30MHFC	