

NOTE: TO BE USED WITH 15" X 24" STANDARD TRENCH DRAIN

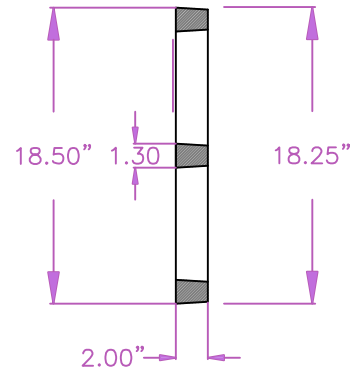

SECTION A-A

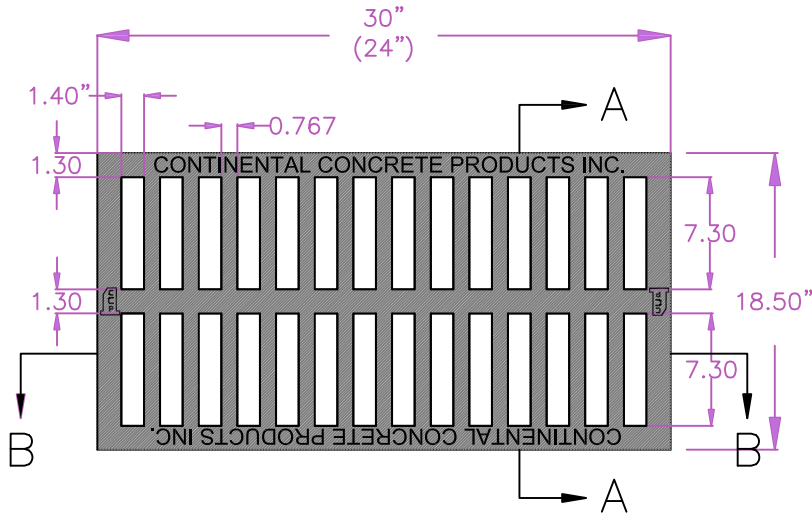
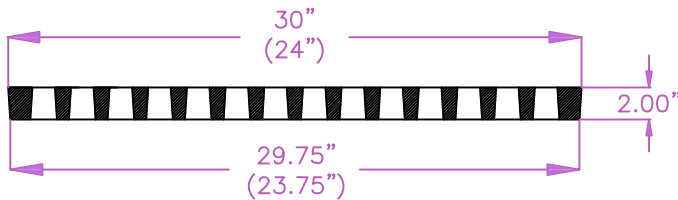

SECTION B-B

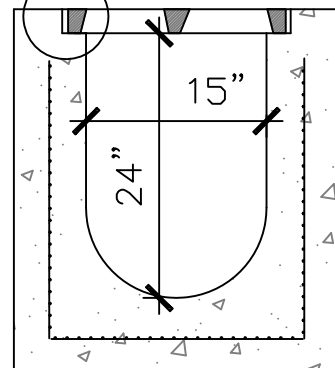
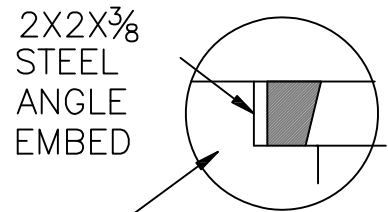

SECTION VIEW

SPECIFICATIONS:

MINIMUM CONCRETE STRENGTH 4000 PSI @ 28 DAYS (PENNDOT CLASS AA)
 MATERIALS AND WORKMANSHIP IN ACCORDANCE WITH THE REQUIREMENTS
 OF PENNDOT PUBLICATION 408 SECTION 605 & 714
 STEEL REINFORCEMENT A615 GRADE 60 HORIZONTAL AND VERTICAL



**Continental
Concrete
Products, Inc.**
 1 South Grosstown Rd.
 Pottstown, PA 19464
 Phone: (610) 327-3700
 Fax: (610) 327-9488

15" X 24" STANDARD TRENCH DRAIN GRATE

SIGNATURE OF APPROVAL

DATE

AR

DWG

STRUCTURE

2/08/16

15x24_TDG